



Case Study

Ethernet over DSL

Augsburg Verkehrs GmbH, Germany



Von hier. Für uns.

Stadtwerke Augsburg

Energie, Wasser, Verkehr.

Application

Ethernet over DSL

Challenge

Offer the convenience of paying for tickets with a debit or credit card by connecting 136 ticket machines

Solution

RAD's ASMi-52 SHDSL modems and LRS-24 modem racks.

Benefits

- Requires only a one-time investment
- Permanent online connection makes disruptions controllable and guarantees high transmission reliability
- Resistance to electromagnetic fields produced by high-tension wires
- Operates in harsh environments

Features

- SNMP-based graphical element management software
- Remote configuration
- Solid metal enclosure with rail mounting
- Adjusts to changing transmission characteristics

RAD's SHDSL Modems Enable Tramway Passengers to Buy Tickets with Credit Cards

When Augsburg Verkehrs GmbH, the public utility company in the Bavarian city of Augsburg, decided to offer tramway passengers the convenience of paying for their tickets with a debit or credit card, they selected an advanced SHDSL solution from RAD Data Communications to connect ticket vending machines to an online system.

The solution, based on RAD's ASMi-52 modems and LRS-24 modem racks, was supplied by SCALTEL, one of RAD's German distributors.

Mobile or SHDSL Technology?

The first decision that the authorities in Augsburg had to make was to select the appropriate technology, a choice between mobile communications and DSL. A mobile communication solution would have been much more expensive, since the ticket machines would have had to have been linked to the central office over a GSM network using dial-up modems. Given that the city's public utilities company already owned its own copper and fiber data network, the decision was quickly made in favor of DSL, which required only a one-time investment. In addition, DSL's permanent online connection makes disruptions controllable and guarantees high transmission reliability. The type of DSL was also chosen quickly. "Due to the long distances that needed to be covered and the high demands made on transmission reliability, SHDSL technology was the only alternative," explained Marcel Vogl, Pre-Sales Manager at SCALTEL. Another decisive advantage of this technology is its resistance to the electromagnetic fields that can be produced by the high-tension wires used as the tramway's overhead lines.

"It was important for us to have a system that is also able to operate reliably in harsh environments typified by large fluctuations in temperature."

Ludwig Nerb, head of Electrical Systems at Augsburg Stadtwerke

RAD

data communications

The SHDSL access solution connects 136 ticket machines at the streetcar stops via existing copper lines over the company's fiber-based Metro Area Network. Up to 18 ticket machines in any one area of the city combine to form eleven cells. RAD's ASMi-52 modems use a point-to-point DSL line to connect each ticket machine in a cell. Depending on the distance – a maximum of ten kilometers – a two-wire or four-wire configuration is used. A RAD LRS-24 rack equipped with ASMi-52 dual/quad modem cards picks up the DSL lines and forwards the data to an Ethernet switch. The switch then bundles this information and transmits it via a RAD ETX-22 media converter to the core network. RADview SNMP-based graphical element management software enables easy system monitoring as well as performance testing and guarantees high performance reliability.

Convincing Advantages

Due to its undeniable advantages, the RAD solution proved very convincing. "Once the decision was made in favor of an SHDSL solution, SCALTEL convinced us to go with the RAD products and proved to us over a test circuit that this technology was able to satisfy our requirements," said Ludwig Nerb, head of Electrical Systems at Augsburg Stadtwerke. "It was important for us to have a system that is also able to operate reliably in harsh environments typified by large fluctuations in temperature," Nerb explained. "This is where the rail version of the ASMi-52, with its solid metal enclosure, scored points, and the rail mounting saves space as well," he continued. "In addition, the modems adjust to changing transmission characteristics, which provides us with high performance reliability."

The modems are also easy to operate. Thanks to the RADview management system, they can be configured from the central office. Remote software upgrades are also possible.

"We are very pleased with the successful installation of our solutions by the Augsburg public utilities company," commented Volker Bendzuweit, General Manager of RAD Data Communications Germany. "A particularly robust infrastructure is very important, especially as far as public transportation is concerned, and we are happy that we were able to demonstrate the reliability of our SHDSL technology."

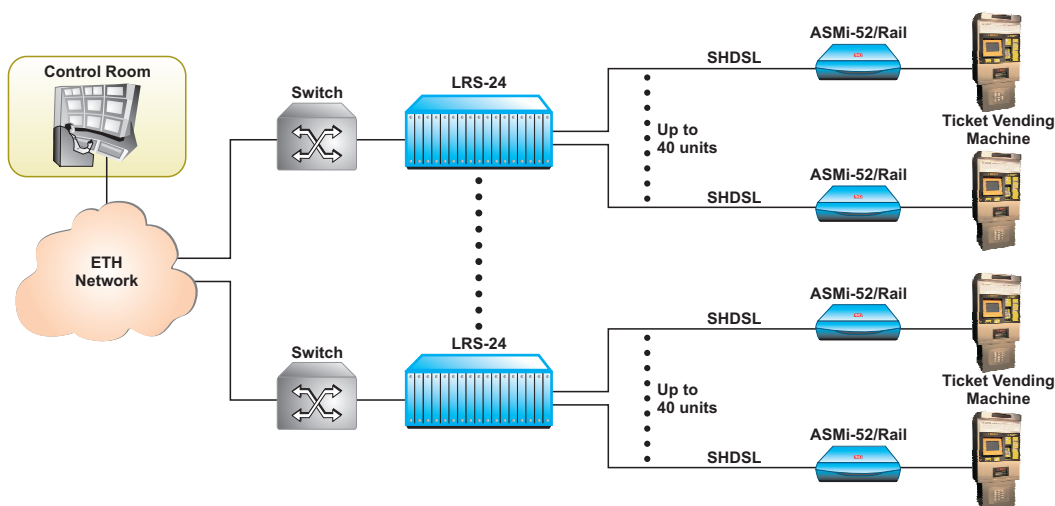

"The rail version of the ASMi-52, with its solid metal enclosure, scored points, and the rail mounting also saves space as well."

Ludwig Nerb, head of Electrical Systems at Augsburg Stadtwerke

Corporate Headquarters

RAD Data Communications Ltd.
24 Raoul Wallenberg Street
Tel Aviv 69719, Israel
Tel: 972-3-6458181
Fax: 972-3-6498250
email: market@rad.com

RAD Germany

RAD Data Communications GmbH
Otto-Hahn-Str. 28-30
85521 Ottobrunn-Riemerling, Germany
Tel: 49-89-665927-0
Fax: 49-89-665927-77
email: info@rad-data.de
www.rad-data.de

www.rad.com



data communications